

FACTS and HVDC Technologies for the Development and Enhancement of Future Power Systems

A. Sumit Kumar Sah¹

*Department of EEE, SRM University Kattankulathur Chennai 603203, India
 E-mail: sksumitsah@gmail.com*

Abstract—The fast development of power electronics based on new and powerful semiconductor devices has led to innovative technologies, such as high voltage dc transmission (HVDC) and flexible ac transmission system (FACTS), which can be applied in transmission and distribution systems. This paper has discussed the application of high voltage power electronics FACTS and HVDC controllers, needs of advance FACTS and HVDC based control for future power system and enhancing system stability and its development. HVDC and FACTS offer major advantages in meeting these requirements.

Keywords—Flexible ac transmission system (FACTS), High-voltage dc transmission (HVDC), FACTS devices, Power system development and reliability, power system controllers

1. INTRODUCTION

The rapid development of power systems generated by increased demand for electric energy initially in industrialized countries and subsequently in emerging countries led to different technical problems in the systems, e.g., stability limitations and voltage problems. However, breaking innovations in semiconductor technology then enabled the manufacture of powerful thyristors and, later of new elements such as the gate turn-off thyristors (GTO) and insulated gate bipolar transistors (IGBT). Development based on these semiconductor devices first established high-voltage dc transmission (HVDC) technology as an alternative to long-distance ac transmission.

HVDC technology, in turn, has provided the basis for the development of flexible ac transmission system (FACTS) equipment which can solve problems in ac transmission. As a result of deregulation, however, operational problems arise which create additional requirements for load flow control and needs for ancillary services in the system.

This paper summarizes the system development and the application of power electronic equipment, HVDC, and FACTS in power systems, the following advantages are discussed in this paper to explain how greater performance of power network transmission with various line reactances can be achieved.

- (a). Reduced maintenance
- (b). Better availability
- (c). Greater reliability
- (d). Increased power
- (e). Reduced losses
- (f). Cost-effectiveness

2. POWER SYSTEM DEVELOPMENT HVDC

During the state of power exchange in interconnected lines to a substation under variable or constant power, the HVDC converters comprehend the power conversion and later stabilize the voltage through the lines giving a breakeven margin in the power transmission.

A. Development

The first large-scale thyristors for HVDC were developed decades ago. HVDC became a conventional technology in the area of back-to-back and two-terminal long-distance and submarine cable schemes [3]. However, only few multi-terminal schemes have been realized up to now. However, further multi-terminal HVDC schemes are planned in the future (Fig. 1).

The main application area for HVDC is the interconnection between systems which cannot be interconnected by ac because of different operating frequencies or different frequency controls. This type of interconnection is mainly represented by back-to-back stations or long-distance transmissions when a large amount of power, produced by a hydropower plant, for instance, has to be transmitted by overhead line or by submarine cable. HVDC schemes to increase power transmission capability inside of a system have been used only in a few cases in the past. However, more frequent use of such HVDC applications can be expected in the future to fulfill the requirements in deregulated systems.

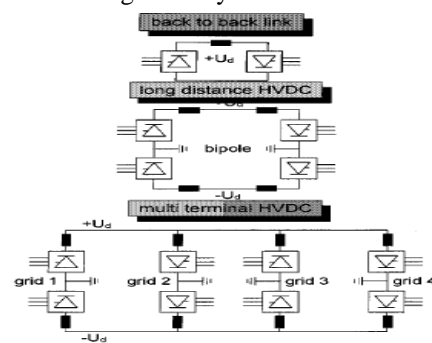

Figure 1. Various types of HVDC connection

B. HVDC Advantages

An important advantage of HVDC is that it can be applied in cases where an AC interconnection is not possible because of technical problems. It offers technical and economical benefits, such as:

- Lower line costs;
- No need for common frequency control;
- Stable operation even with a low-power interconnection;
- Improved dynamic conditions in ac systems

C. Flexible AC Transmission System (FACTS)

The objective of incorporating FACTS into the power system lines are similar to HVDC but greater flexibility are involved like improving real power transfer capability in the lines, prevention of sub-synchronous resonance (SSR) oscillations and damping of power swings [1]. FACTS devices have four well-known types which are used in many power systems in the world [1, 2, 4, 9]. ‘Single’ type controller is the types of FACTS that installed in series or shunt in an AC transmission line, while ‘unified’ type controller are the combined converters type of FACTS controllers like UPFC and HVDC. The size of a controller is dependent on the requirements of the network and desired power transmission at loading point Voltage Source Controller (VSC) is sinusoidal voltage and is used in power system and other application. The quality of the sine wave is dependent on the size or amount of the power electronics installed. The following types of FACTS devices are VSC type based controllers:

Shunt controller: example device, STATCOM emulates like a variable inductor or can be a capacitor in shunt or parallel connection in the transmission line. This type of device is capable of imitating inductive or capacitive reactance in turns to regulate line voltage at the point of coupling. Shunt controller in general controls the voltage injection [2, 9].

Series controller: example device, SSSC emulates like a variable inductor or a capacitor in series with a transmission line and it imitates inductive or capacitive reactance in turn to regulate effective line reactance between the two ends. Series controller in general controls current injection [2, 9].

Shunt-series controller: can be a standalone controller as STATCOM and SSSC. This type of controller is a reactive compensator with the exception of producing its own losses. It is also recognized as “unified” controller and requires small amount of power for DC circuit exchange occurring between the shunt and series converters [2]. See Fig.2 for shunt-series controller.

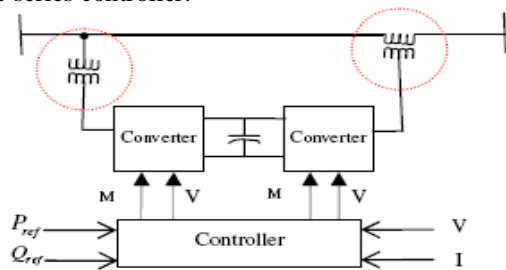

Figure 2 Series-shunt compensator, UPFC [6]

The driving force behind the development of power systems is the growing demand for electric energy. In the industrialized countries of Europe and North America, and also in Japan, we expect slow demand growth, even stagnation, despite a high present level of demand. In Asia, and partly in South America and Africa, growth is still expected to be rapid. These are the regions where the increase in energy demand will be greatest in the near future. This

expected fast rise in energy demand will likewise lead to further rapid development of electric energy systems.

As power supplies are built up in developing countries, consumption per inhabitant at first rises only slowly. As an initial step, local networks are set up to supply individual towns and villages. In these local networks, which can use small renewable energy sources such as solar, wind, or diesel, power electric equipment for distribution systems can be applied to interconnect these elements to the system. Medium voltage direct current transmission (MVDC) can be used to bridge greater distances with low voltage and low power. As energy demand continues to grow, higher voltage levels are needed. In newly industrializing countries, where demand is increasing rapidly, not only thermal power plants are used, but existing hydropower potential is also being developed. Some generation may, however, be far away from the expanding load centers. At this point considerable investments in the high-voltage network are required for introducing higher voltage levels and/or HVDC transmission.

In the beginning, ac transmission has to transfer relatively low power over long distances. Technical problems, such as voltage control and dynamic stability, do arise, but they can be alleviated by shunt and series compensation. However, FACTS offering the possibility of fast control is much more effective at solving these problems [3].

In the industrialized countries, with their highly developed systems and minimal rise in demand, however, we are facing other problems. It is almost impossible to establish new routes for overhead lines and cables. Where power density is high transmission and distribution networks must be upgraded and the proportion of decentralized power supplies is growing for reasons of economy, not just politics. In such countries it is no longer possible to construct large power plants at convenient locations near the loads. Lower cost energy can be imported from far away because of economic reasons usually via HVDC.

This general development in power systems is, however, superimposed by the trend towards deregulation, which is opening up a power market and giving customers the opportunity to buy energy at a more favorable price. This changing environment decisively influences the optimization of the transmission network since the load flows existing today will be altered considerably. The ancillary functions required for smooth operation of the networks, such as frequency control, load-flow control, reactive-power and voltage stability, as well as the responsibility for network security, are being assumed by the operators. New installations are needed, e.g., FACTS equipment in the system or additional purchases of ancillary services from the power plants or other transmission companies. These additional requirements for power systems can be effectively met by using FACTS equipment.

3. THE CURRENT STATUS OF POWER ELECTRONIC TECHNIQUES, FACTS AND HVDC

A. Power Electronics

The core or the “workhorse” of HVDC and FACTS installations are high-power thyristors, triggered optically by means of laser technology or electrically depending on

application. Thyristors can only switch on the current. The switching-off is carried out by the next current zero crossing itself; this is the reason why a thyristor converter is referred to as a line-commutated system. Should no line voltage be available on one side of an HVDC system or in a FACTS application, the system is no longer functioning. An advantage of thyristor converters is their high loading capacity both during nominal and overload operation as well as in the event of contingency. Consequently, bulk power systems at high transmission capacities of 5 to 7 GW can be implemented with thyristor only. A further benefit consists in comparatively low station losses.

Power electronics have a wide spread range of applications from electrical machine drives to excitation systems, industrial high current rectifiers for metal smelters, frequency controllers and electric trains. FACTS devices are just one application besides many others that have followed the same technology trends of power electronics. The history of power electronics started from 1965 with the first Thyristor rectifiers, and development has not stopped since. Power electronics have evolved to the present modularized IGBT, IGCT, IEGT or ETO voltage source converters.

B. THYRISTOR

The Thyristor is a device, which can be triggered with a pulse at the gate and remains in the on-state until the next current zero crossing. Thyristors have the highest current and blocking voltage, and are still the device with the highest voltage and power levels. This means that fewer semiconductors need to be used for each application. Thyristors can be used as switches for capacitors or inductors, and in converters for reactive power compensators. HVDC based thyristor technology is still the only possible AC-DC transmission approach with a voltage level above 500 kV and power above 3000 MW.

These devices are being used in high-voltage direct-current transmission systems. At present, no other device type can match the performance of thyristors, and their application for long distance and large power transmission with very high power is expected to continue in the foreseeable future.

C. IGCT

To increase controllability, GTO (Gate Turn Off) Thyristors were developed, and can be switched off with a voltage peak at the gate. These GTO based devices are now replaced by IGCT (Insulated Gate Commutated Thyristors), which combine the advantages of low on stage losses and low switching losses. These semiconductors are used in smaller FACTS devices and drive applications. The GTO thyristors have also been developed over the past 30 years. Their main advantages over thyristors have been in the higher switching the anode to cathode voltage. These attributes have led to the use of GTOs in high power inverter systems.

D. IGBT and IEGT

The IGBT (Insulated Gate Bipolar Transistor) has become an important power electronic technology in FACTS applications. The device takes advantage of the high voltage

bipolar transistor with MOS gate. Basically an IGBT can be switched on with a positive voltage and switched off with a zero voltage. This characteristic allows a very simple gate drive unit to control the IGBT. The voltage and power level of the applications is up to 300 kV and 1000 MVA for VSC HVDC.

IEGT (Injection Enhancement Gate Transistor) chips are the latest in fast recovery diode technology, and are an advanced standard package design. They create a compact, high-efficiency and high-isolation 6.5kV, 1.2kA IEGT module, which uses trench gate semiconductor technology. The IEGT has high power ratings comparable to the GTO and can be operated at high speed comparable to the IGBT. The latest IEGT module combines low thermal resistances with reduced on-state losses and a 3000 reduction of off-state losses is realized when compared with conventional modules. In addition, the size of an IEGT module is about one third of that of a GTO module.

E. ETO Thyristor

An ETO (Emitter Turn-Off) thyristor combines the best characteristics of IGCT and IGBT with a high current carrying capability and a medium voltage of GTO is considered as one of the emerging high-power semiconductor devices. The ETO Thyristor was initially developed as an extremely high-power switching device to be used in power conversion systems within electric utility grids. The ETO Thyristors are capable of switching up to 4 kA of electric current and 6 kV of electric voltage. The ETO Thyristor has the following technical characteristics:

- (a) 5000A snubber-less turn-off capability;
- (b) Low switching losses & conduction losses;
- (c) Low cost device and circuit;
- (d) Easy for series and parallel operation;
- (e) Low gate drive power;
- (f) Built-in over-current protection and current sensor;
- (g) Easy for mass-production.

F. FACTS and HVDC Controllers

FACTS Controllers

for Transmission Systems

- Static Var Compensator (SVC)
- STATCOM
- Thyristor Controlled Series Compensator (TCSC)
- Static Synchronous Series Compensator (SSSC)
- Thyristor Controlled Phase Angle Regulator (TCPAR)
- Unified Power Flow Controller (UPFC)

for Special Applications

- NGH Scheme for SSR Damping
- SMES
- Thyristor Controlled Braking Resistor (TCBR)
- Thyristor Controlled Voltage Limiter (TCVL)
- Current Limiter

Figure 3. FACTS controllers.

There are two categories of FACTS devices available. Thyristor switched and/or controlled capacitors/reactors such as SVC (Static Var Compensator) and TCSC (Thyristor Controlled Series Compensator) were introduced in the late 1970s while Voltage-Sourced Converter-based FACTS devices such as STATCOM (Static Synchronous Compensator), SSSC (Static Synchronous Series Compensator) and UPFC (Unified Power Flow

Controller) were introduced in the mid 1980s. In the past, there has been a large number of SVCs installed in electric utilities. There are tens of conventional line commutated BTB (Back-to-Back) speed and the ability to turn off the current without reversal of HVDC, a number of STATCOM and TCSC, three UPFCs, one IPFC and a number of VSC HVDC with BTB configuration installed within electric power systems around the World. It is anticipated that more STATCOM and VSC HVDC will be installed in the future.

All FACTS devices and HVDC links are helpful in stability control of power systems. The shunt type FACTS device is more useful to control system voltage and reactive power while the series type FACTS device is more suitable for power flow control. The series-shunt type controller – UPFC can be used to control the active and reactive power flow of a transmission line and bus voltage independently. The series type FACTS controller - IPFC (Interline Power Flow Controller) can be used to control power flows of two transmission lines while the active power between the two transmission lines can be exchanged. The newly developed VSC HVDC, which has similar control capability as that of the UPFC, can control both the independent active and reactive power flows of a transmission line and the voltage of a local bus [7]. However, the HVDC based conventional line commutated converter technique cannot provide voltage control and independent reactive power flow control. Another very important feature of VSC HVDC technique is that it can be very easily configured into a multi-terminal VSC HVDC. Research indicates VSC HVDC is a viable alternative to the UPFC for the purpose of network power flow and voltage control.

FACTS devices based on VSC techniques can be interconnected to implement various configurations and structures for different control purposes. While thyristor switched and/or controlled capacitors/reactors have limited performance and functionality, converter-based devices have superior performance, versatile functionality and various configuration possibilities. One shortcoming with converter based devices is, they are more expensive. With the continuous effort in R&D, it is likely that the costs of converter-based devices will be reduced further, and hence they will be more widely used in the next 5-10 years.

4. FACTS AND HVDC CONTROLS OF THE FUTURE POWER SYSTEM

A. Renewable energy sources: Challenges to the grids

Sustainability of power supply stands for a number of measures for efficiency enhancement – with regard to power generation, it means the increase in efficiency ratio during energy conversion at a power plant, the reduction in transmission losses in the grid and, last but not least, efficiency enhancement at the load. The decisive role in terms of sustainability is played by the renewable energy sources, particularly those capable of producing entirely CO₂-free power, such as hydro, solar and wind energy.

B. Needs of Advanced FACTS and HVDC based Control for Future Power Systems

It has been recognized that some transmission systems are not yet designed for the deregulated energy market. Power system infrastructure needs modernization as future power systems will have to be smart, fault tolerant, dynamically and statically controllable, and energy efficient. As discussed in the previous section, the interconnected transmission network needs either to be enforced or to be upgraded to a super power grid using FACTS and HVDC technologies. The super power grid may be a mixture of high voltage AC and HVDC links plus FACTS devices for provision of secure and reliable power transmission.

FACTS and HVDC will be helpful to provide fast dynamic voltage, power flow and stability control of the power grid while enhancing efficient utilization of transmission assets. At the same time network congestion will be efficiently managed and system blackouts will be mitigated or avoided.

C. Integration of Wide Area Stability Control and Protection with FACTS and HVDC Control against System Blackouts

The wide area stability control and protection system is considered the "eyes" that overlook the entire system area, and can capture any system incidents very quickly; while FACTS and HVDC are the "hands" of the system, which have very fast dynamic response capability and should be able to take very quick actions as soon as commands are received from the system operator. As the current situation stands, the fast dynamic control capability of FACTS and HVDC has not been fully explored and realized. The integration of the Wide Area Stability Control and Protection with FACTS and HVDC control will fully employ control capabilities of both technologies to achieve fast stability control of system, and to prevent the system against blackouts. Hence, a high network security and a reliable performance can be achieved.

In order to tackle large-scale stability disturbance and protect the transmission system against blackouts, a coordinated control of the integrated power network is required using the advanced stability control methodologies and/or wide area monitoring and control by using FACTS and HVDC control technologies. In order to fulfill the requirement of wide area monitoring control, Phasor Measurement Units (PMU) are required to be installed in some portal substations, which can provide necessary information for wide area control. In addition, a system operator of the interconnected EU network is essential to coordinate the operation and control of the system reliably and safely.

D. FACTS and HVDC for Distributed Generation

FACTS and HVDC can be applied in transmission systems to improve the voltage, power flow and stability control. They can also be applied in the interconnection of distributed generation to power grids in order to satisfy the connection requirement of distributed generators in compliance with the Grid Codes. In recent years, a number of VSC HVDCs with BTB structure have been applied in the

wind generation interconnection with the grid thanks to the voltage, active and reactive power control capability provided by the BTB VSC HVDC. In the future, for some applications, a multi-terminal VSC HVDC configuration may be used.

FACTS controllers such as SVC and STATCOM can be applied to control voltage of wind generators, as voltage usually fluctuates. STATCOM, which has the ability to regulate voltage smoothly and quickly and provide continuously dynamic reactive support, will find wide application in this aspect. STATCOM integrated with energy storage will give the device greater influence such that dynamic active and reactive power flow control may be achieved.

STATCOM devices can be used to achieve voltage and power flow control for wind generation, power quality control for preventing voltage dips; voltage swells; fault ride through and stability control. In order to fully employ the capabilities of FACTS, use of the energy storage integrated with FACTS will be a viable solution in providing multifunctional controls for voltage fluctuations, power flow and power quality in a single device.

5. FUTURE DEVELOPMENT OF FACTS AND HVDC

The development of future FACTS and HVDC requires:

- (a) Reduction of overall costs
- (b) Improvement of reliability
- (c) Structural modularity and scalability
- (d) Mobility and relocatability
- (e) Internal fault-detecting and protection capabilities
- (f) Openness to third party product connectivity

A. Reduction of Overall Costs

It seems likely that continuous R&D effort will reduce the overall cost of VSC by 25 to 30%, because no auxiliary components are needed for harmonic cancellation; transformer-less series controllers can be developed; identical building block module structure for partial availability can also be developed; wide-frequency band control operation will become fast and effective; and protection action during abnormal operation conditions and contingencies will become feasible.

B. Improvement of Reliability

With the advances in IEGT, ETO or other power electronics switch techniques, reliability will be improved due to the application of simplified circuits and advanced packaging techniques. As there are an enormous number of chips in a power system converter, a single chip failure would not lead to malfunction of an entire FACTS device.

C. Structural Modularity and Scalability

The concept of modularity comes from computer software engineering; modularity has been applied to hardware architecture, institutional organization and structure, etc. A

Modular design should have a clear architecture, clean interfaces, and a set of well-specified functional tests of each module's performance. The design of IBM's 360-

mainframe computer is a good example for explaining modularity. The IBM system was designed to have various parts, called modules. The modules were designed and produced independently of one another, but, when combined, they worked together seamlessly. As a result, all mainframe computers built out of the 360 modules could run the same software. Furthermore, new modules could be added to the system, and old ones upgraded without rewriting code or disrupting operations.

The H-bridge Building Block is a modular-designed VSC, which has easy-to-expand voltage and power ratings by adding building blocks in series or shunt connections. Modular design of VSCs will therefore be convenient for maintenance and easy to diagnose for fault or failure of hardware.

Scalability is a very important design concept in electronics systems, computer systems, databases, routers, and networking; it implicitly implies performance. A system, whose performance improves after adding hardware, proportionally to the capacity added, is said to be a scalable system. System scalability makes system expansion simple and easy, hence upgrading the system is more feasible.

D. Mobility and Re-locatability

In electricity market environments, the uncertainty of the system demand becomes a real challenge. In this situation, it is preferable that FACTS devices can be mobilized and should be reloadable according to the system demand distribution. In this way, the stranded transmission investment costs may be avoided, and hence the uncertainty of planning can be hedged.

E. Functional Flexibility

Functional flexibility requires a FACTS device to provide more than one control function or control possibility. In addition, the FACTS device should be expandable to realize interconnections with other FACTS devices or storage devices. For instance, two STATCOMs may be configured into either a BTB VSC HVDC or a UPFC.

F. Hybrid FACTS Controllers

Due to the high cost of FACTS devices, hybrid FACTS may be constructed by combining traditional devices with FACTS devices in order to expand functionality. For instance, a Quadrature Booster (QB) transformer (as shown in fig 4) may be combined with a TCSC to realize independent active and reactive power flow control.

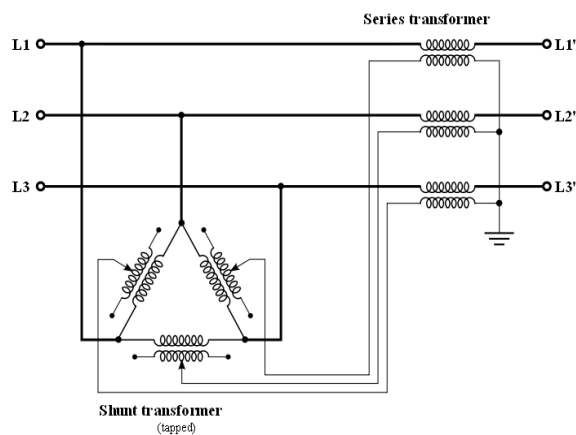

Figure .4 Quadrature Booster (QB) transformers [5]

G. Intelligence-Based Monitoring and Diagnostic System for FACTS and HVDC

An intelligence-based monitoring and diagnostic system for FACTS and HVDC will be able to monitor and diagnose any early warnings for potential failure of power electronic components, and therefore corrective actions may be taken before any malfunctions occur.

6. CONCLUSIONS

This paper presents a review of problems experienced by power systems of today, and the current status of applications of power electronic techniques such as FACTS and HVDC in power systems. In order to ensure that the transmission system is flexible enough to meet new and less predictable supply and demand conditions, The primary control objectives of future power systems are:

- (a) To facilitate electricity trading;
- (b) To optimize the overall performance and robustness of the system;
- (c) To react quickly to disturbances to minimize their impact and prevent the system against blackouts and;
- (d) To restore the system to the normal operating level after a disturbance.

FACTS and HVDC solutions together with advanced communication, computing and control technologies will fulfill the above requirements. With the continuous effort in R&D of control technologies, it is likely that the costs will be further reduced, and hence they will be more widely used in electric power grids in the next 5 to 10 years.

REFERENCES

- [1] J.W. Evan, "Interface between automation and Substation," *Electric Power substations engineering*, J.D. Macdonald, Ed. USA: CRC Press, 2003, pp. 6-1 (Chapter 6).
- [2] N.G. Hingorani, L. Gyugyi, "Understanding FACTS," New York: IEEE Press, 2000, pp. 2, 29, 135, 300 and 417.
- [3] D. Povh, *Trends in HVDC*, V. Sepope Symp., Recife, Brazil, May 1996.

- [4] J. Arillaga, "Flexible AC Transmission technology," Y. H. Songs, and A.T. Johns, Ed. UK: Steven age, Herts IEE., 1999, pp. 99.
- [5] <http://en.wikipedia.org/wiki/File:Qb-3ph.svg>.
- [6] E.M. Yap, M. Al-Dabbagh and P.C Thum, "Using UPFC Controller in Mitigating Line Congestion for Cost-efficient Power Delivery," Submitted at the Tencon 2005, IEEE conference, May 2005. E.M. Yap, M. Al-Dabbagh, "Applications of FACTS Controller for Improving Power Transmission Capability," submitted at the IPEC 2005, IEEE conference, May 2005.
- [7] X.-P. Zhang, "Multiterminal Voltage-Sourced Converter Based HVDC Models for Power Flow Analysis", *IEEE Transactions on Power Systems*, vol. 18, no. 4, 2004, pp. 1877-1884.
- [8] D J Hanson, C Horwill, B D Gemmill, D R Monkhouse, "ATATCOM-Based Reloadable SVC Project in the UK for Nationalrid", in Proc. 2002 IEEE PES Winter Power Meeting, New York City, 7- 31 January 2002. uip_2.pd
- [9] A. Edris, "Technology Developments Applications of power electronics-Based controller on transmission grid," [Online] Available. http://www.electricity.doe.gov/documents/gridworks_wshop/util_perspe